

TE253 Series

Programmable Digital Room Thermostats

3-speed Fan and Modulating Control Used with 6-Port Valve

OPERATION MANUAL

Front view

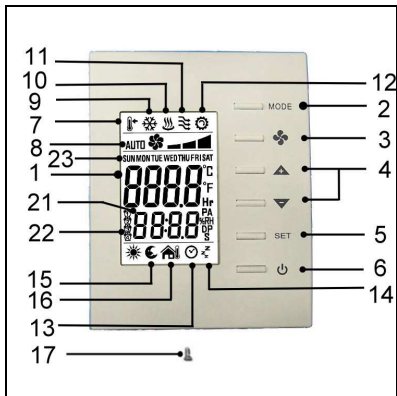

Back view

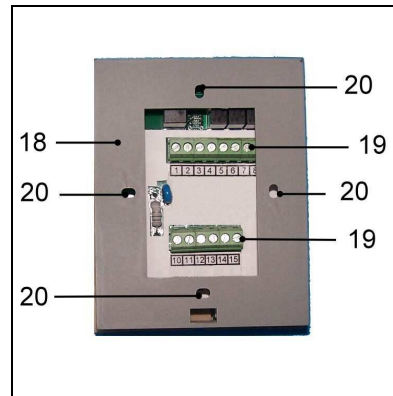

#	Item	Description
1	LCD	Display temperature and working status.
2	MODE button	Access to user and engineer menu and for setting confirmation or change °C/°F unit if press for over 3 sec.
3	FAN button	Toggle to change Fan mode: Auto or Continuous
4	UP & DOWN buttons	Increase & decrease setting or previous/next item
5	SET button	Setting for schedules and Timers
6	On/Off button	Turn on/ off Valve and Fan
7	Set-point icons	Displaying set-point temperature while it is flashing
8	Fan icons	Indicate Fan status
9	Flake icon	Indicate working on Cooling mode;
10	Hot spring icon	Indicate working on Heating mode
11	Flow icon	NA
12	Gear icon	Indicate cooler is ON
13	Clock	NA
14	Sleep	NA
15	Moon Sign	Indicating room is unoccupied via occupancy contact
16	Outdoor icon	NA
17	Cover screw	Screw to tighten back cover with front cover
18	Back plate	Plate for mounting on electric box
19	Wiring terminal blocks	Terminals for wiring
20	Mounting holes	Holes for mounting on electric box
21	Time	Display time
22	Schedule number	Current Schedule running or setting
23	Day	Current day of Sunday ~ Saturday or setting

Installation

Mounting on electric box

1. Separate back plate from the controller by loosening the cover screw;
2. Align the mounting holes on the screw holes of the electric box (applicable to 65x65 or US standard box);
3. Fix the back plate on the electric box by tightening the back plate screws. Suggest to use Philips wider "truss head" or "washer head" #6-32x 3/4" (20mm).
4. DO NOT let the bolt head rise above the wall of mounting holes of back plate. It might cause the short circuit of the controller.

Mounting front cover

1. Lock front cover on the back plate by tightening the cover screw underneath with screw driver of Philip electronic instrument type or similar.

Wiring Example

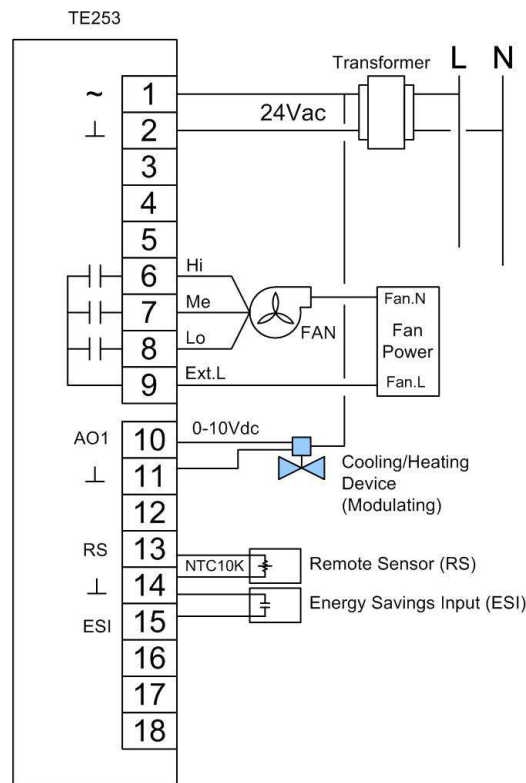

Wiring diagram for TE253 thermostat

1. All wires coming from the electric box must be inserted above the retainers of the respective terminal block before tightening the captive screws;

I/O





Direct/ Inverse	AO1(0~4.5VDC)	AO1(5.5~10VDC)	DO (Hi/Me/Lo)	RS	ESI
Direct	Heating Output	Cooling Output	3-speed Fan Control	Remote Temperature Sensor(NTC10K)	Occupancy
Inverse	Cooling Output	Heating Output	3-speed Fan Control	Remote Temperature Sensor(NTC10K)	Occupancy

Operation

User Mode Operation

The first tier of operation includes the following settings as Figure 2. To operate:

1. Power switch  "ON" or "OFF" to start/ stop the System;
2. After switching "ON", press any button to start the User Mode operation.
 - i. Press "MODE" button to switch over different working modes. When MODE is pressed for more than 3 seconds, the unit of temperature will toggle to change to °F or °C.
 - ii. Press UP/ DOWN button to increase/ decrease or rotate the values of setting.
 - iii. Press "FAN" button to toggle over different fan modes.
 - iv. Press "SET" button to set current time-date and timer. When SET is pressed for more than 3 seconds, users can set the temperature schedules.
3. It will return to normal display with the latest setting if there's no button pressed for 10 seconds.

#	Item	Description	Remarks
1	Normal Display	Display Current Room or Set-Point Temperature and Current Time-Day.	Setting "-SP- "Parameter in Engineer Table to Choose Current Room or Set-Point Temperature.
2	Temperature Setting 	View Current Set Point or Set The Required Temperature	
3	Mode Select 	1. Select The Working Mode: (1) Run/ Halt/ Stop for Schedule 2. When MODE Is Pressed For More Than 3 Seconds, The Unit Of Temperature Will Toggle To Change To °F Or °C.	RUN: Run Schedules. HALT: Pause "Current" Schedule and Use Manual SP. STOP: Stop Using All Schedules and Use Manual SP.
4	Fan Auto/ Continuous 	Change Fan mode for Auto speed or continuous Low/Med/Hi speed.	
5	Time/ Date/ Schedule Setting 	1. Set Current Time in 12- Or 24- Hour Format; 2. Set Calendar and Day of Week; 3. When SET Is Pressed for More Than 3 Seconds, Users Can Set Temperature Set Points Schedules	Press SET to Continue Settings. Press MODE, FAN, Or POWER Button to Escape Any Time During Setting.

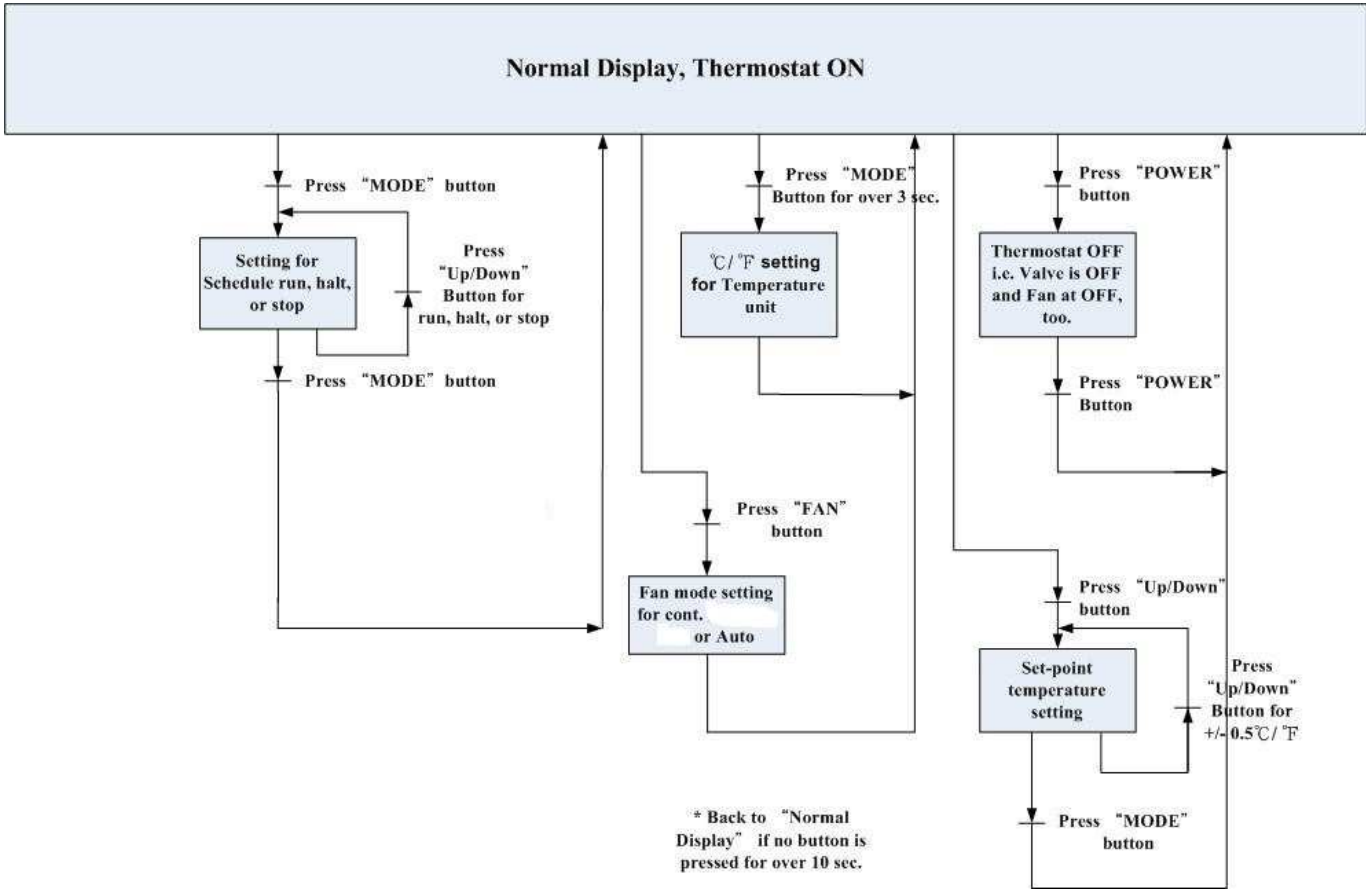
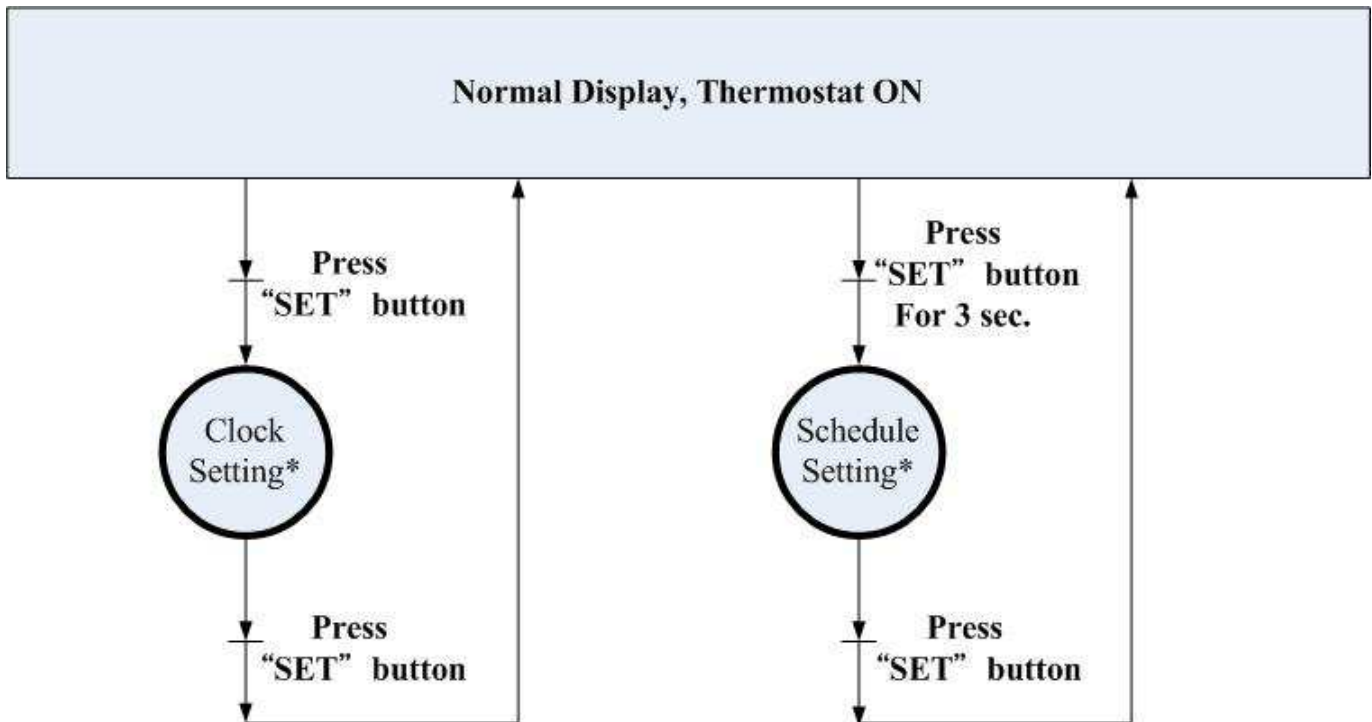

Fig. 2 User Mode operation sequence

Overview for the settings of Clock and Schedules



* Please refer to its related detailed state diagram respectively for details.

📖 Press MODE, FAN, or POWER button to escape any time during setting.



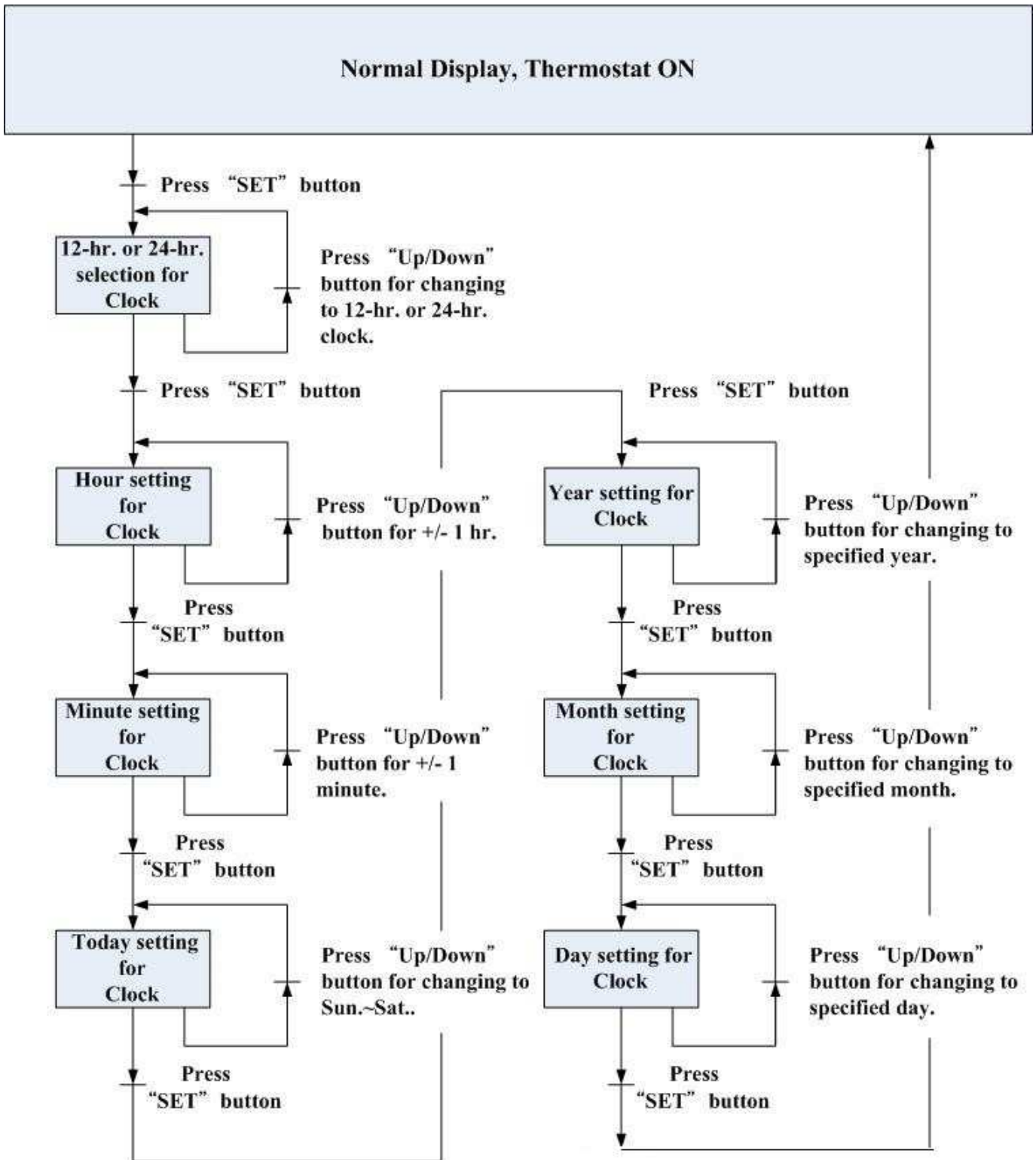

1. Detailed State Diagram for Clock Setting

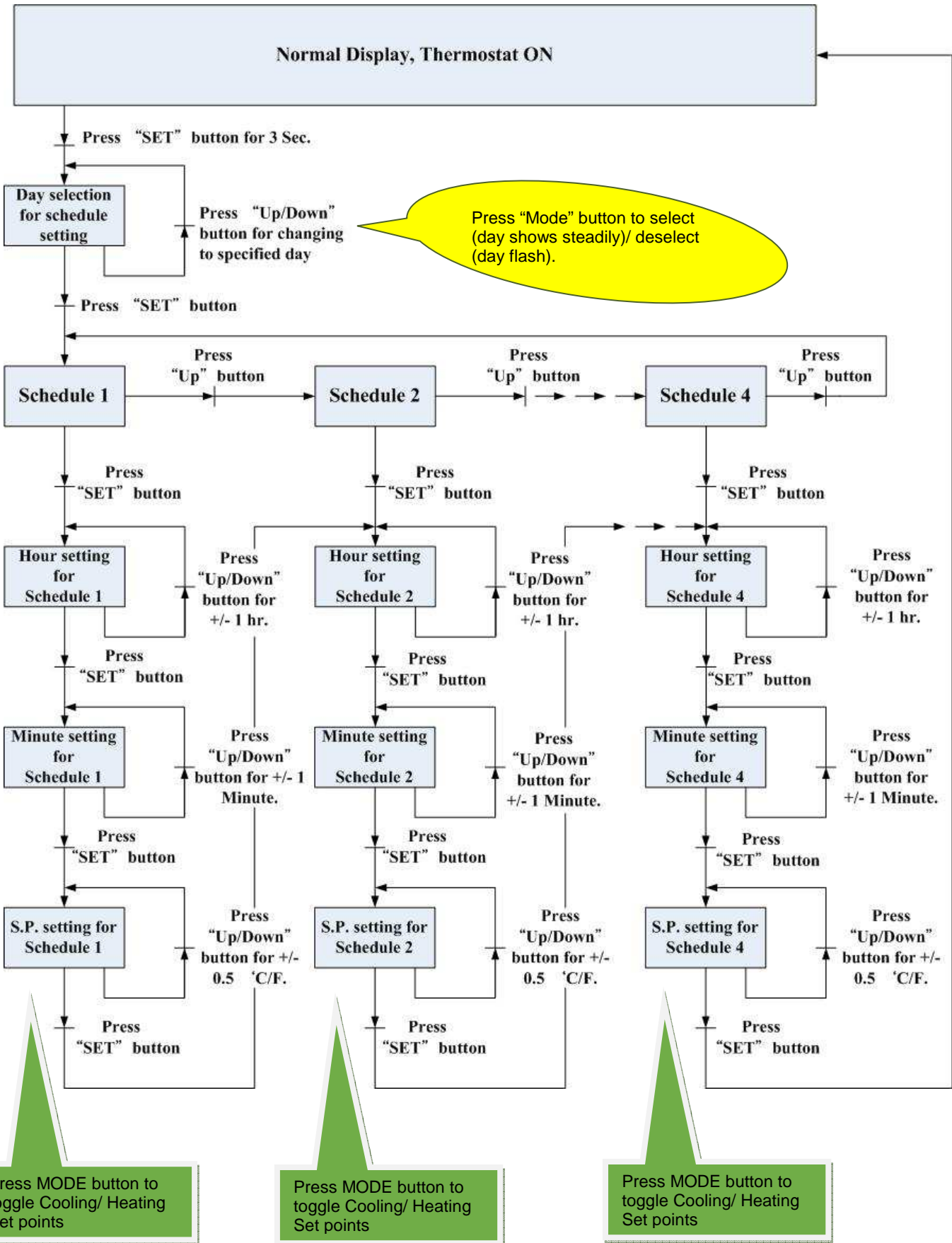





2. Detailed State Diagram for Schedule Setting



Default Set Point Schedules

COOL	Sun	Mon	Tue	Wed	Thu	Fri	Sat
Sch. 1 	6:00 26.0°C	6:00 26.0°C	6:00 26.0°C	6:00 26.0°C	6:00 26.0°C	6:00 26.0°C	6:00 26.0°C
Sch. 2 	8:00 29.5°C	8:00 29.5°C	8:00 29.5°C	8:00 29.5°C	8:00 29.5°C	8:00 29.5°C	8:00 29.5°C
Sch. 3 	18:00 26.0°C	18:00 26.0°C	18:00 26.0°C	18:00 26.0°C	18:00 26.0°C	18:00 26.0°C	18:00 26.0°C
Sch. 4 	22:00 26.0°C	22:00 26.0°C	22:00 26.0°C	22:00 26.0°C	22:00 26.0°C	22:00 26.0°C	22:00 26.0°C

HEAT	Sun	Mon	Tue	Wed	Thu	Fri	Sat
Sch. 1 	6:00 21.0°C	6:00 21.0°C	6:00 21.0°C	6:00 21.0°C	6:00 21.0°C	6:00 21.0°C	6:00 21.0°C
Sch. 2 	8:00 16.0°C	8:00 16.0°C	8:00 16.0°C	8:00 16.0°C	8:00 16.0°C	8:00 16.0°C	8:00 16.0°C
Sch. 3 	18:00 21.0°C	18:00 21.0°C	18:00 21.0°C	18:00 21.0°C	18:00 21.0°C	18:00 21.0°C	18:00 21.0°C
Sch. 4 	22:00 16.0°C	22:00 16.0°C	22:00 16.0°C	22:00 16.0°C	22:00 16.0°C	22:00 16.0°C	22:00 16.0°C

- **Unoccupied Set Points:** activated by occupancy contact; Cooling: 28.0°C/ Heating: 15.0°C
- When **schedules are activated**, refer to cooling/ heating set points according to current schedule.
- When **pause or stop schedules**, refer to manual set point or latest set point as Cooling Set Point and dead band for Heating Set Point deviation.
- Scheduled Cooling Set Point range: 10.0°C ~ 37.0°C; Heating Set Point range: 4.5°C ~ 32.0°C; make sure to set heating lower than cooling set point to have proper controls.

Control Actions





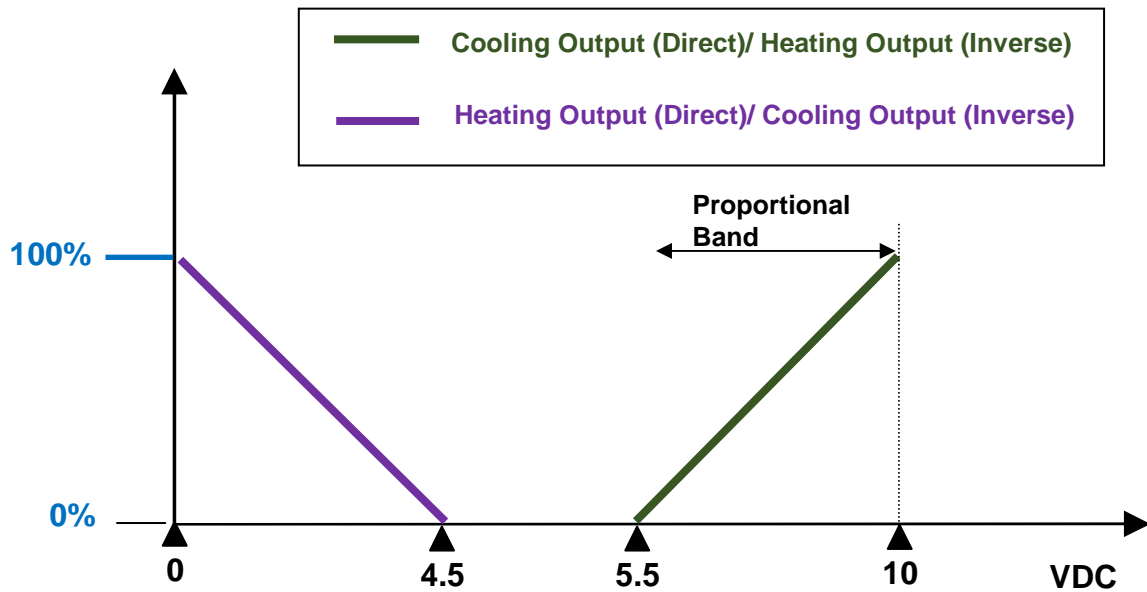

6-Port Valve Controls:

(1) **Valve Output Fine Tune:** Valve output allow minimum adjustment (**AO1 Low(E5)**) from 0-2 Vdc and maximum adjustment (**AO1 High(E6)**) from 8 to 10 Vdc. These two output voltages can be gauged by multimeter lively during setting to reflect the setting change effects.



(2) When Cooling or Heating is open, a “Running (Gear) ()” icon will be shown on the LCD.





Special:

1. Fan bar will be shown according to the fan output reaches low speed, medium speed or 100% of max fan output.
2. ESI (Energy Saving Input) Contact status -- When the contact is activated (Room unoccupied), a “Moon ()” icon will be shown on the LCD and the thermostat will change the set-point temperatures of Cooling & Heating to be ESIC & ESIH (refer to Engineer table for details.). When the contact is deactivated (Room back to be occupied), it will set the set-point values back as normal.
3. If disable local ESI contact detection, the room will become always occupied status as default.
4. The icon  ,  ,  , or  will be shown on LCD while the Schedule 1,2,3, or 4 is running or being set.
5. If press “MODE” button, there are three schedule modes “RUN, HALT, and STOP” for selection.
 - a.) RUN mode means activating Schedules. And at the same time an icon ( ~ ) will be steadily shown on the LCD.

b.) HALT mode means temporarily pause current schedule and using manual S.P instead. And the icon

( ~ ) will be flashing on the LCD.

c.) STOP mode means stop to use manual S.P until manually activate schedule again. And the icon ( ~ )

will be NOT shown on the LCD.

Engineer Mode Operation

This mode is highly suggested to be operated by trained engineers because it is related to system parameters that will affect the control results. To operate:

1. Press “Up” and “Down” buttons for over 5 seconds to enter into engineer mode;
 2. Press UP or DOWN button to rotate the menu item and press MODE button to enter into the item;
 3. Press UP or DOWN button to change the setting and press MODE button to confirm the setting and return to menu item selection. For no button pressed for 10 seconds, it will go back to menu item selection. The setting won't be changed then.
 4. To leave Engineer Mode, rotate till “End” and press MODE button or leave the button intact for 10 seconds.
- Engineer mode operation flow chart:

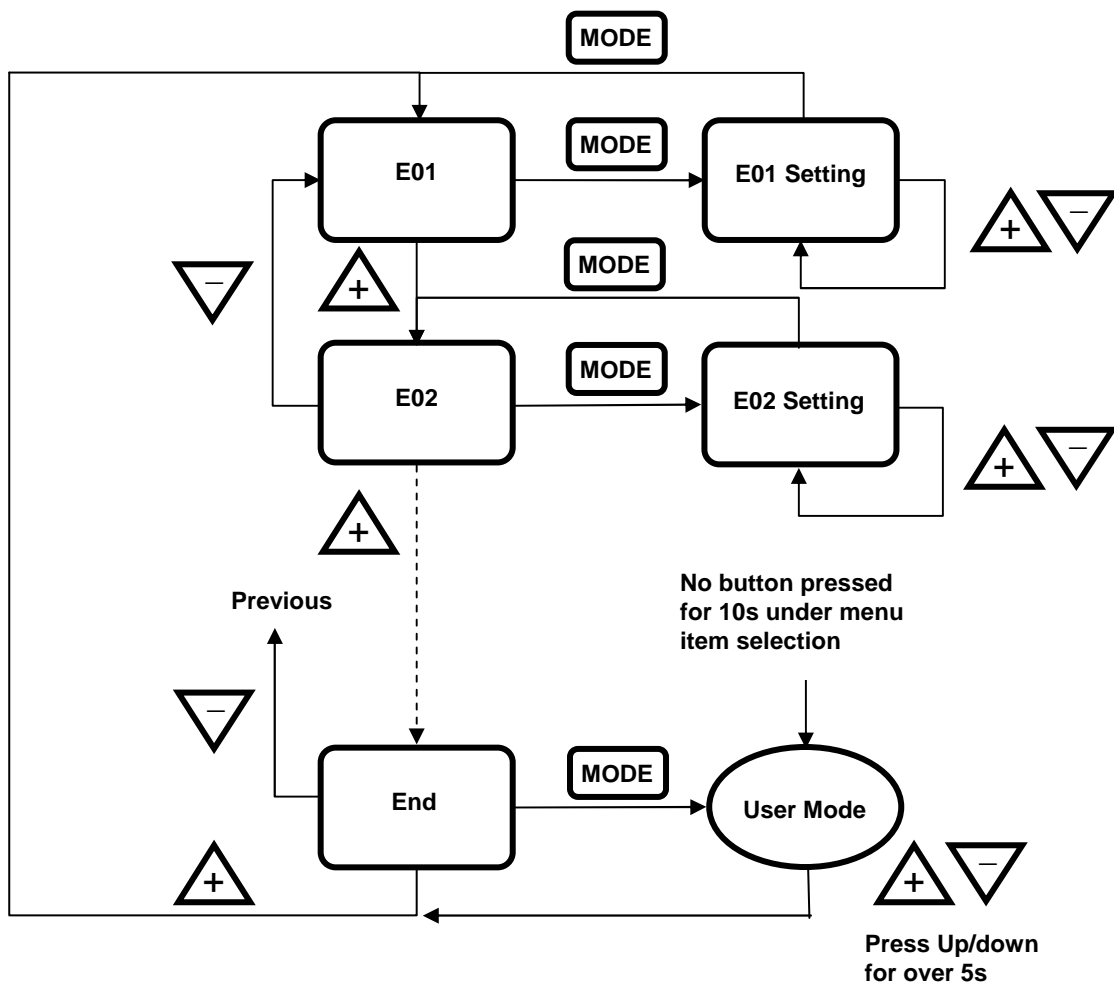

Fig. 3 Engineer Mode operation sequence

Engineer mode menu item descriptions:

Item	Mnemonic	Description	°C Type		°F Type		Step
			Default	Range	Default	Range	
E1	db	Deadband	2.0	0~10.0	3.5	0~18.0	0.5 (°C/°F)
E2	ESIC	Unoccupied(ESI) Cooling Set Point	28.0	25.0~35.0	82.0	77.0~95.0	1.0 (°C/°F)
E3	ESIH	Unoccupied(ESI) Heating Set Point	15.0	10.0~22.0	59.0	50.0~72.0	1.0 (°C/°F)
E4	I-t	Integral Time and Output Cycle Time	90	10~500	90	10-500	10 (Sec.)
E5	AO1L	Analog Output 1(Valve) Low Adjustment	0	0~50	0	0~50	1(~0.044V)
E6	AO1H	Analog Output 1(Valve) High Adjustment	-25	-50~0	-25	-50~0	1(~0.044V)
E7	AO2L	Not Used					
E8	AO2H	Not Used					
E9	SP-L	Low Limit for Temperature Set Point	10.0	0~50.0	50.0	32.0~122.0	1.0 (°C/°F)
E10	SP-H	High Limit for Temperature Set Point	35.0	0~50.0	95.0	32.0~122.0	1.0 (°C/°F)
E11	OFS	Current Temperature Offset	0.0	-10.0~10.0	0.0	-18.0~18.0	0.1 (°C/°F)
E12	Pb	Proportional Band or Stage Width	2.0	0~10.0	3.6	0~18.0	0.1 (°C/°F)
E13	LOC	Bit Definition --- Bit 0: Mode Button 1: Down Buttons 2: Up Button 3: Fan Button 4: Power Button 5: Set Button 6: ESI Contact Detection 7: Door/Window Contact ct detection *Bit Value 0: Unlock / enable 1: Lock / disable Examples: 0- Unlock/enable all 1- Lock MODE Button 2- Lock Down Button ... 8-Lock Fan Button ... 15-Lock MODE & Down & Up & Fan Buttons 16-Lock Power Button ... 64-Disable ESI contact detection ... 128-Disable Door/Window contact detection ... 255- Lock/disable all	0	0-255	0	0-255	1

E14	ESI	ESI Contact Definition	0	0~1	0	0~1	0: N.O. 1: N.C.
E15	rS	Present Temperature Is Getting from Built-In Temperature Sensor, or Remote Temperature Sensor.	0	0~1	0	0~1	0: built-in 1: remote
E16	-SP-	Display Present Value of Temperature or Set-Point for Normal Displaying	0	0-1	0	0-1	0: display PV 1: display SP
E17	FAnL	Not Used					
E18	Fan2	Not Used					
E19	nFan	Minimum FAN speed at AUTO Fan mode	0	0~3	0	0~3	0: stop 1: low 2: Med. 3: Hi
E20	dIrr	Direct/ Inverse Action of AO1	0	0/ 1	0	0/ 1	0: Direct 1: Inverse
E21	tESt	Self-Diagnostic					
E22	rSt	Reset All Parameters to Factory Defaults					
E23	End	Exit Engineer Mode					